



# Step Inside a Compact Elegance Home Lift

Reliable, Affordable and Easy to Install Lifts.



^Terms and conditions apply. Ask our staff for additional information.



## The Compact Elegance Home Lift Range

### Specifically designed to fit easily into your home.

The Compact Home Lift range works on the principle of the lift car travelling on self supporting rails, requiring no load bearing walls.

In most instances, a simple ceiling aperture is all the building work required. The lift rails affix to the lower level floor, the aperture insert and the ceiling of the upper level, providing strength and stability the lift requires.

The Compact Lift range offers a vast array of safety specifications including internal and external lift car safety sensors and concealed mobile phone connected to our 24-hour emergency service centre, so you can have absolute confidence in your lift.



### The Elegance

The Elegance is a 2 person lift with a 170kg capacity and remarkably small 0.8m<sup>2</sup> footprint.

The clear dome lift car body of the Elegance helps it blend and fit into any room configuration.



### The Elegance Plus

The Elegance Plus is one of the smallest vertical wheelchair lifts on the market, with a 1.44m<sup>2</sup> footprint and 250kg lifting capacity.

The Elegance Plus includes the same safety features as the Elegance, with the convenience of a larger cabin size and angled ramp for ease of wheelchair or walker access.



### The Elegance Plus Thru-Car

The Elegance Plus Thru-Car gives you ease of access from both sides of the lift car, allowing you to enter and exit from the front or back of the lift unit.

This model is ideal for installation in stairwell voids or split level homes, offering an access solution whilst maximising your living space.

# Why Choose a Compact Home Lift?



## Peace of mind

In the event of an emergency while operating your lift, an emergency phone is concealed in the lift and allows you to dial our 24-hour Emergency Service.



## Small footprint

Our range offers an extremely compact footprint with the Elegance measuring 0.8m<sup>2</sup> and the Elegance Plus 1.44m<sup>2</sup>.



## Remote control

Your Home Lift comes with two remote control handsets included. Additional handsets can be purchased if required.



## Safety Sensors

Multiple sensors are fitted internally and externally to every Compact Home Lift to ensure that everyone remains safe both inside and outside the lift.



## In-car control panel

The in-car control panel is extremely easy to use with push button, hold-to-operate controls. The control panel is also fitted with LED display lights illuminating if lift operation is being compromised.



## Emergency Power Supply

In the event of a power failure occurring whilst the lift is in operation, each lift is fitted with a back up battery which will activate automatically allowing you to move the lift safely to the lower level.

# Compact Home Lifts Features & Benefits



## Small Footprint

The Elegance footprint is a remarkably small 0.8m<sup>2</sup>. The slightly larger Elegance Plus footprint will accommodate a standard-sized wheelchair, and has a footprint of 1.44m<sup>2</sup>.



## Quiet

German engineered motor that is whisper quiet and completely hidden away in the lift car roof space. There are no noisy hydraulics with a Compact Home Lift.



## Delivery & Installation

Stocked locally and includes a fast 1-2 day standard installation, once the ceiling aperture has been created by a qualified builder.



## In House Builders

Should you require a builder, we strongly recommend our preferred in-house, registered and very reputable building specialists.



## Power Consumption

A Compact Home Lift plugs into a single standard 10 amp domestic power socket. When running it uses less energy than if you were to boil a kettle.



## Unique Guide System

The self supporting structure of the vertical rails bear the entire load of the lift. No additional burden is placed on the structure of your home.



## Self Contained Drive System

The self contained drive system is concealed in a space within the roof area of the lift car. Therefore, no need for an additional plant room/cabinet or other machinery.



## Level Access

The Elegance Plus comes with a gently angled ramp to enable convenient entry for wheelchair users.



## Half Height Gate & Electric Door Lock

A half-height gate is fitted as standard with a monitored electric lock that ensures the lift car door stays closed while the lift is moving, releasing only when it has reached its destined stop. Full-height gate options also available.



## Full Height Light Curtain

All lifts are equipped with a full-height safety light curtain, creating a barrier across the entrance of the lift, stopping the lift from moving further if there is an obstruction.



## Safety Sensors

There are safety sensors in the lift car base and roof which will stop the lift from operating if it comes into contact with any obstruction.



## GST

Our products qualify for a GST exemption if purchased with the intent to overcome mobility issues.



## Warranty

We provide a market leading 7-year warranty. Terms and conditions apply, ask our staff for additional information.

# Typical Lift Installation Applications

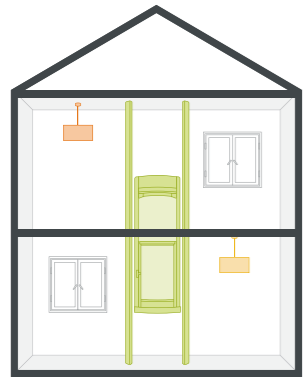

## Standard

This is our most popular configuration, the Home Lift will travel between a downstairs room such as living room and arrive upstairs, typically in a bedroom.

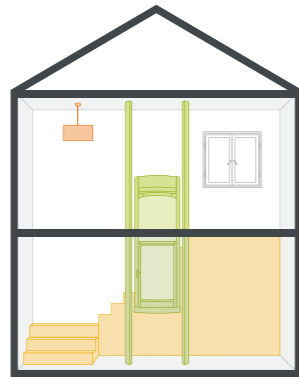

## Stairwell void/landing

Where there is enough room in the turn of a staircase, this positioning option makes use of the dead space in the void making the Home Lift even more unobtrusive.



## Cupboard

Thanks to the compact nature of a Compact Home Lift, you can choose to have your lift completely hidden by installing it inside an airing cupboard or wardrobe.

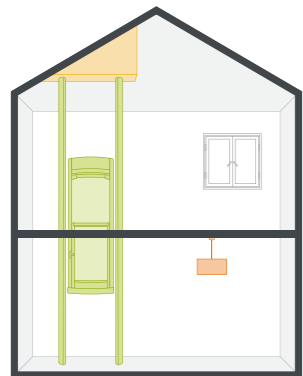

## Sloping/vaulted ceilings

Our vertical rails need to fix to a horizontal surface. But don't worry if you have a vaulted ceiling. Our building teams can provide subtle solutions to overcoming pitched roof installations.

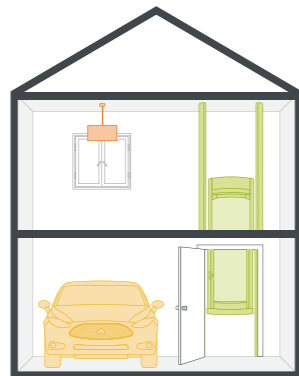

## Garage

If you are looking to get from your garage safely into your home we can build a simple shaft around your Compact Home Lift to take into account health and safety considerations.

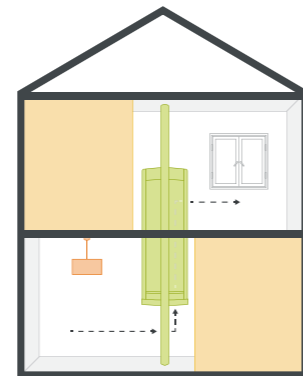

## Thru-Car

Unique to the Compact Elegance Plus is the Thru-Car concept. Enter and exit through opposite sides of the lift car - ideal for wheelchair users or for lifts built into a stairwell void.

# Lift Footprints

## The Elegance Footprint

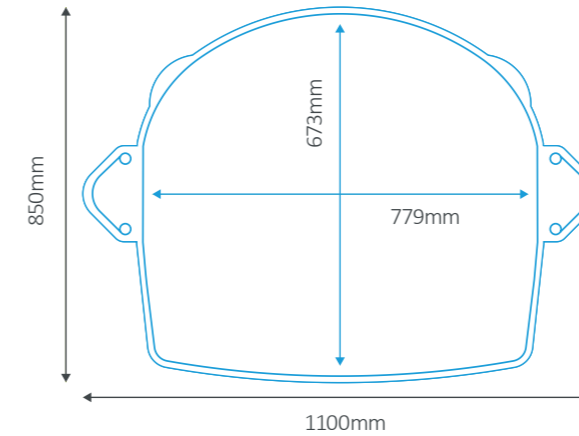

## The Elegance Plus Footprint

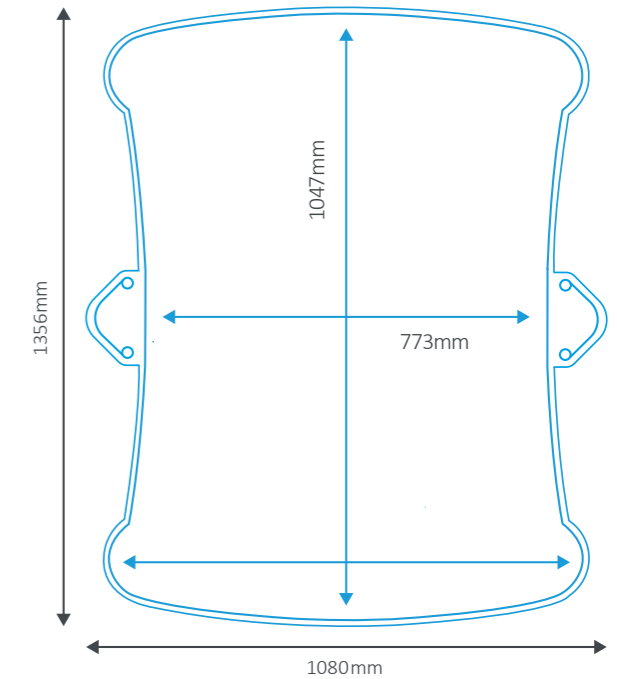

## Technical Specification

<b>REGULATION</b>	Australian Design Registration
<b>MAX TRAVEL</b>	4500mm floor to floor travel
<b>POWER SUPPLY</b>	230V socket - plugs into a normal 10amp power socket
<b>LOAD CAPACITY</b>	Max. 170kg / 2 people
<b>DRIVE</b>	Self-contained wire rope hoist system located in the top of the lift car
<b>SPEED</b>	up to 0.1m / sec
<b>DIMENSIONS</b>	1940mm internal lift car height 779 x 673mm internal cabin floor 1100 x 850mm overall footprint 587 x 1100mm lift entrance
<b>LIFT CAR DOOR</b>	1100mm hinged half-height door or full-height door options available. Full-height light curtain will protect entire door height
<b>ILLUMINATION</b>	Contemporary ambient lighting with high-quality LED strips
<b>CONTROL</b>	Lift is controlled via the control panel and two remote controls. Additional remote controls are available upon request
<b>HEADROOM</b>	A minimum upper floor ceiling height of 2400mm is required
<b>ENTRANCE CONFIGURATION</b>	Single entrance only

## Technical Specification

<b>REGULATION</b>	Australian Design Registration
<b>MAX TRAVEL</b>	4500mm floor to floor travel . 6000mm available upon special request
<b>POWER SUPPLY</b>	230V socket - plugs into a normal 10amp power socket
<b>LOAD CAPACITY</b>	Max. 250kg / 2-3 people
<b>DRIVE</b>	Self-contained wire rope hoist system located in the top of the lift car
<b>SPEED</b>	up to 0.1m / sec
<b>DIMENSIONS</b>	1940mm internal lift car height 773 x 1047mm internal cabin floor 1356 x 1080mm overall footprint 800 x 1100mm lift entrance
<b>LIFT CAR DOOR</b>	1100mm hinged half-height door or full-height door options available. Full-height light curtain will protect entire door height
<b>ILLUMINATION</b>	Contemporary ambient lighting with high-quality LED strips
<b>CONTROL</b>	Lift is controlled via the control panel and two remote controls. Additional remote controls are available upon request
<b>HEADROOM</b>	A minimum upper floor ceiling height of 2430mm is required
<b>ENTRANCE CONFIGURATION</b>	Single entrance or through entrance available



Get in touch for more information on how a Compact Home Lift can transform your home and your life.

**NSW Showroom**

647 Botany Road  
Rosebery  
NSW  
2018

**VIC Showroom**

456 Smith Street  
Collingwood  
VIC  
3066

**QLD**

P.O. Box 6357  
Meridan Plains  
QLD  
4551

Phone: **1800 904 088**

Email: [hello@compactlifts.com.au](mailto:hello@compactlifts.com.au)

Visit: [www.compactlifts.com.au](http://www.compactlifts.com.au)

